



HDS DPC-47



HDS DPC-68

STANDARD FEATURES

- Stainless steel top with glass viewing window.
- Bright white painted steel interior and exterior.
- Refrigeration system keeps ice cream at temperatures between -10°F and 5°F (-23°C to -15°C).
- Transparent lids hinged with a full length handle.
- Plastic can holder for each container rack.
- LED lighting.
- Electronic control system makes it easy to adjust temperature set point and defrost frequency.
- Slide out refrigeration condensing unit makes it easy to access condenser for cleaning and service.
- These units use HYDRO-CARBON R290 refrigerant, which is environmentally friendly and more efficient than R134a/R404a refrigerant.

HDS DPC-47

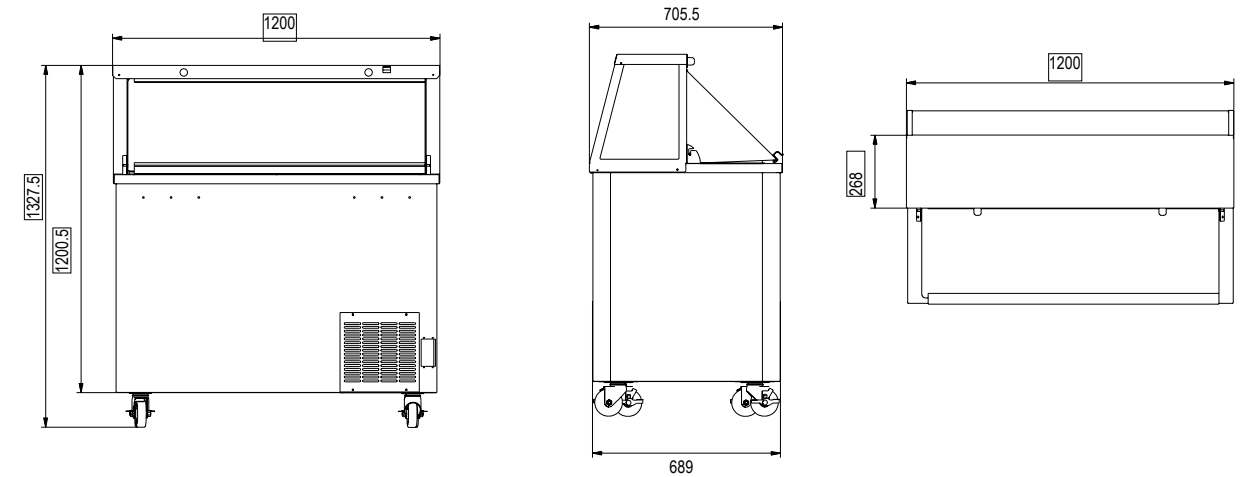

HDS DPC-68

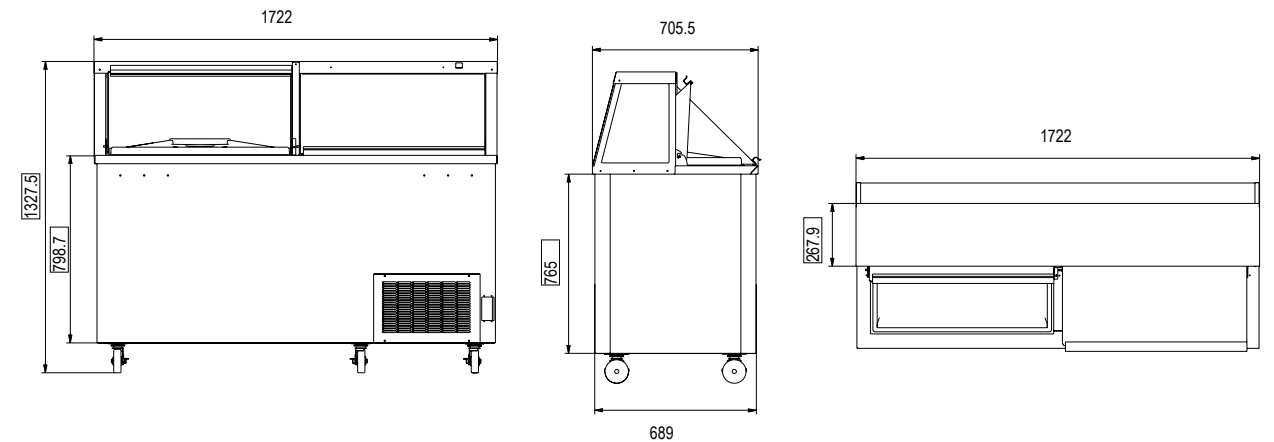

MODEL	DOORS	SHELVES	DIMENSIONS	CAPACITY	HP	AMPS	VOLTAGE	PLUG TYPE
HDS DPC-47	1	8	47 x 27 3/4 x 51 1/8 in 1195 x 705 x 1300 mm	8 cu.ft. 4 liters	1/4+	5.16	115/60/1	NEMA 5-15P
HDS DPC-68	2	12	67 3/4 x 27 3/4 x 51 1/8 in 1720 x 705 x 1300 mm	12 cu.ft. 8 liters	1/2+	5.64	115/60/1	NEMA 5-15P

sales@heavydutysystems.com

Voltage 220/50/1 available.