



HDSDD-24-48



HDSDD-24-60



HDSDD-24-72

STANDARD FEATURES

- Durable stainless steel top, interior walls, floor and ceiling.
- Exterior construction is attractive corrosion resistant vinyl on steel in black finish.
- Refrigeration system keeps the drinks at safe temperatures between 33°F and 41°F (0.5°C to 5°C).
- Electronic control system makes it easy to adjust temperature set point and defrost frequency.
- Shelves: Adjustable heavy-duty PVC coated shelves.
- Option of stainless steel exterior available.
- Preinstalled 4" heavy-duty casters with brakes.
- Option of leveling feet available.
- Self-Closing doors with locks.
- LED interior lighting.
- Slide out refrigeration condensing unit makes it easy to access condenser for cleaning and service.
- These units use HYDRO-CARBON R290 refrigerant, which is environmentally friendly and more efficient than R134a/R404a refrigerant.

HDSDD-24-48

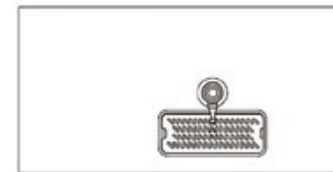
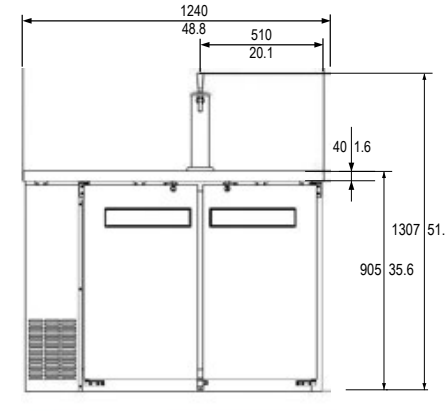

HDSDD-24-60

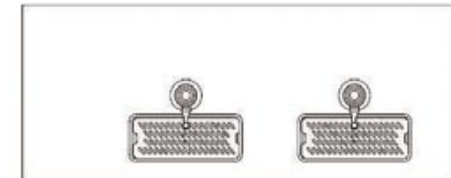
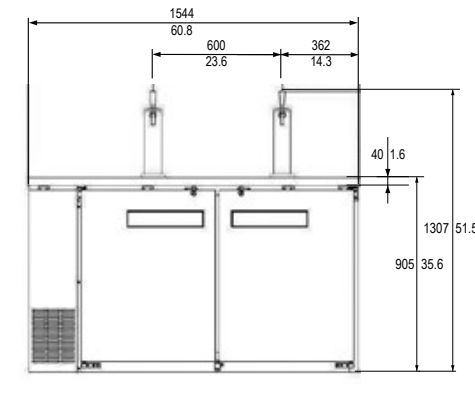

HDSDD-24-72

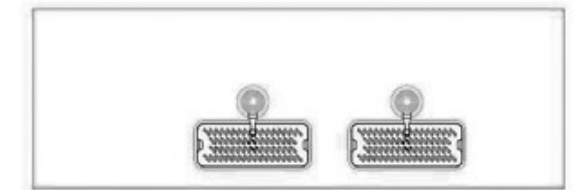
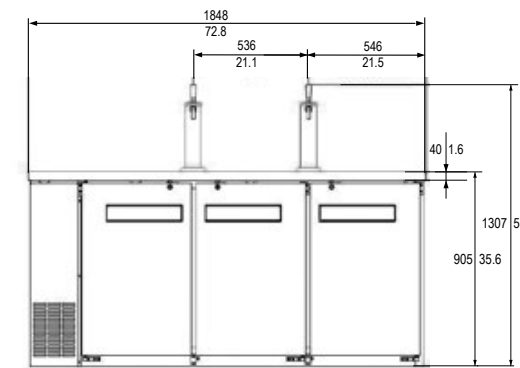

MODEL	DOORS	SHELVES	DIMENSIONS	CAPACITY	HP	AMPS	VOLTAGE	PLUG TYPE
HDSDD-24-48	2	4	48 7/8 x 24 3/8 x 35 5/8 in 1240 x 620 x 905 mm	11.8 cu.ft. 2*1/2 barrel	1/5	3	115/60/1	NEMA 5-15P
HDSDD-24-60	2	4	60 3/4 x 24 3/8 x 35 5/8 in 1544 x 620 x 905 mm	15.8 cu.ft. 2*1/2 barrel	1/5	3	115/60/1	NEMA 5-15P
HDSDD-24-72	3	6	72 3/4 x 24 3/8 x 35 5/8 in 1848 x 620 x 905 mm	19.6 cu.ft. 3*1/2 barrel	1/4	4	115/60/1	NEMA 5-15P

sales@heavydutysystems.com

Voltage 220/50/1 available.