

# Tilting lifter for table

Ribaltatore scarico su tavolo



Standard 3Ph - 50/60Hz

mac.pan

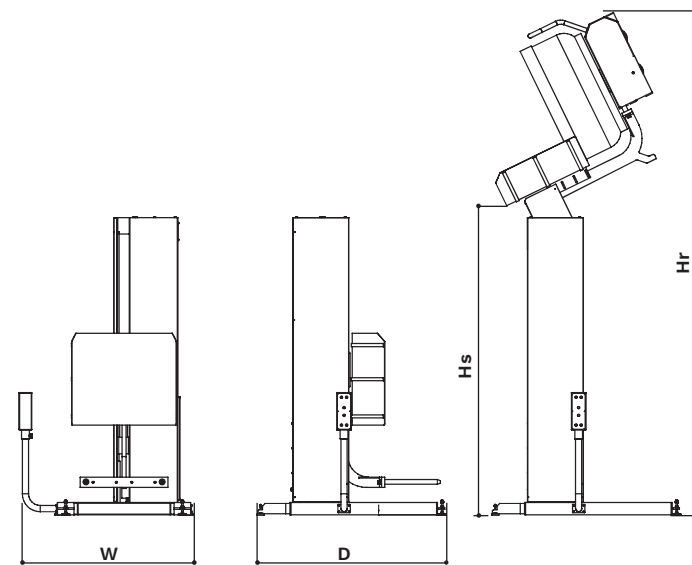

caratteristiche generali • general characteristics

- One electric motor
- Hydraulic lifting system
- double button control
- Quick and easy to clean
- Scraper and bowl rotation (ON REQUEST)
- Stainless steel machine (ON REQUEST)

- Unico motore elettrico
- Sistema di sollevamento idraulico
- Comando a doppio pulsante
- Veloce e facile da pulire
- Raschiatore e rotazione vasca (SU RICHIESTA)
- Macchina inox (SU RICHIESTA)

*Our machines are designed, manufactured and assembled in ITALY. - Le nostre macchine sono progettate, costruite e assemblate in ITALIA.*



★ G • GOLD LINE  
DESIGNED FOR INDUSTRY

MODEL	mixer compatibility	bowl compatibility	power consumption kW	machine dimension cm	H s cm	H r cm	machine weight Kg
RCEB 80	MSPA 80	CS 80	1,1	W150_D150(H145)	120	250	430
RCEB 100	MSPA 100	CS 100	1,1	W150_D150(H145)	120	250	430
RCEB 130	MSPA 130	CS 130	1,1	W150_D150(H145)	120	260	430
RCEB 160	MSPA 160	CS 160	1,1	W150_D150(H145)	120	270	430
RCEB 200	MSPA 200	CS 200	1,1	W150_D150(H145)	120	275	430
RCEB 250	MSPA 250	CS 250	1,1	W150_D150(H145)	120	285	430
RCEB 300	★ MSPA 300 G	CS 300	1,1	W180_D180(H145)	120	295	630
RCEB 400	★ MSPA 400 G	CS 400	1,1	W180_D180(H145)	120	305	630



The tilting lift for the removable bowl saves the operator time and effort when removing the dough from the bowl. Thanks to the oil-hydraulic system, all operations can be carried out safely and silently.

Il Sollevatore ribaltatore per carrello estraibile, consente all'operatore di risparmiare tempo e fatica nell'estrarre l'impasto dalla vasca stessa. Il sistema oleodinamico fornisce inoltre, sicurezza e silenziosità, durante il funzionamento.

*As continued product improvement is a policy of MAC.PAN Srl, specifications are subject to change without notice.*

