

CE

French style fork mixer

Impastatrice a forcella
vasca libera



Standard 3Ph - 50/60Hz
On request 220V - 1Ph - 50/60Hz



mac.pan

caratteristiche generali • general characteristics

This mixer is suitable for medium/soft dough for baguettes and other types of traditional French bread. Equipped with bowl locking system to keep the speed constant. Can be supplied with manual, semiautomatic and automatic controls.

Questa impastatrice è adatta per impasti medio/soffici tipo baguette ed altri tipi di pane tradizionali francesi. Dotata di freno vasca per poter mantenere costante la velocità. Fornibile con comandi manuali, semiautomatici ed automatici.

Our machines are designed, manufactured and assembled in ITALY. - Le nostre macchine sono progettate, costruite e assemblate in ITALIA.



descrizione • description

Model M

Manual fork mixer. 2 speeds, no timer. The mixing time is managed manually by the operator, manual cycle.

Impastatrice a forcella manuale. 2 velocità, no timer. Il tempo di impasto viene gestito manualmente dall'operatore, ciclo manuale.

Model S

Semi-automatic fork mixer. 2 speeds, 1 timer. The mixing time at the selected speed is managed by one single timer, semi-automatic cycle.

Impastatrice a forcella semiautomatica. 2 velocità, 1 timer. Il tempo di impasto nella velocità selezionata viene gestito da un solo timer, ciclo semiautomatico.

Model A

Automatic fork mixer. 2 speeds, 2 timers. Both speeds have their own timer. The switching from speed 1 to speed 2 occurs automatically, automatic cycle.

Impastatrice a forcella automatica. 2 velocità, 2 timer. Ogni velocità è temporizzata da un timer. Il passaggio dalla prima alla seconda velocità è automatico, ciclo automatico.

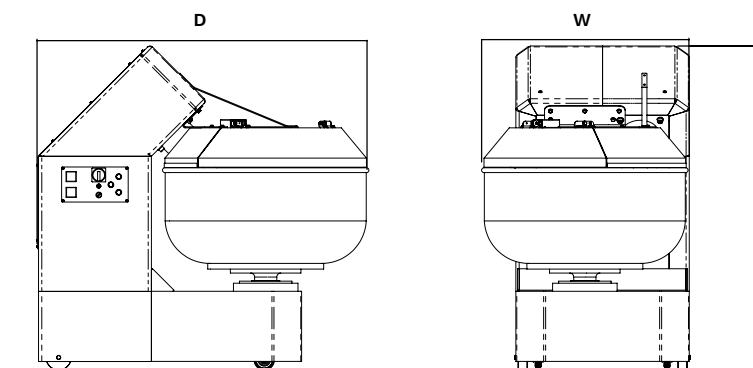

MODEL	dough capacity Kg	flour capacity Kg	bowl capacity lt	bowl diameter cm	power consumption kW	machine dimension cm	machine weight Kg
VL300M	160	100	330	100	3.3/5.1	W115_D150(H120)	525
VL300S	160	100	330	100	3.3/5.1	W115_D150(H120)	525
VL300A	160	100	330	100	3.3/5.1	W115_D150(H120)	525

As continued product improvement is a policy of MAC.PAN Srl, specifications are subject to change without notice.

YouTube

