



HDSGCO-1

STANDARD FEATURES

- Porcelainized cavity finish for easy cleaning
- Double speeds blower to meet demands for different food cooked inside
- Fully visible glazed doors to keep eyes on cooking process any time
- Interior illuminator controlled by switch
- Double stacking options to optimize your kitchen space with same footprint
- Solid state temperature controller
- Strong and robust angular legs for stability
- Stainless steel in the front
- Automatic igniting system for gas safety
- 60 minutes timer as a reminder
- 4 racks, 13 rack positions
- Optional with castors

- **Gas Products available in either Natural or LP Gas setup**
- **Thermostats (if applicable) available in either Fahrenheit or Celsius**
- **Electric Products available in alternate electrical power setups**

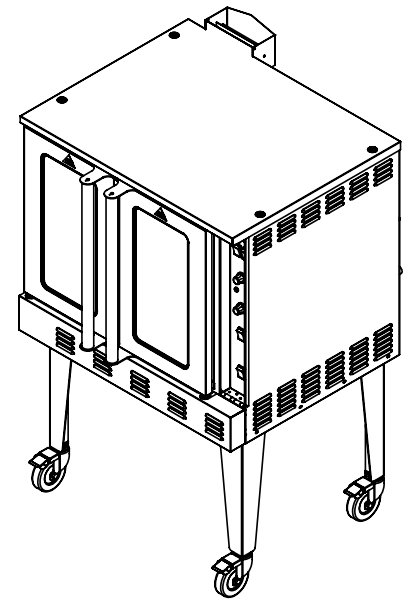
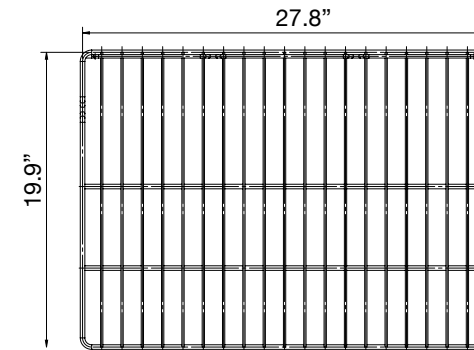
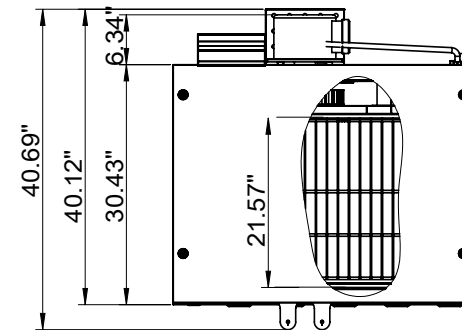
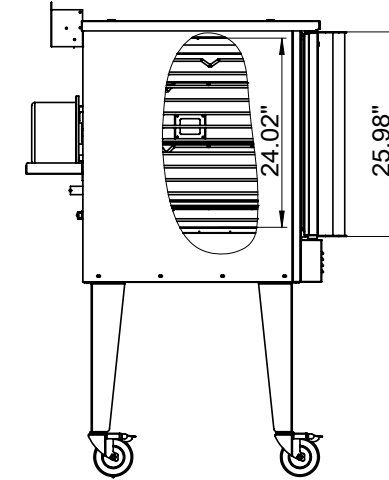
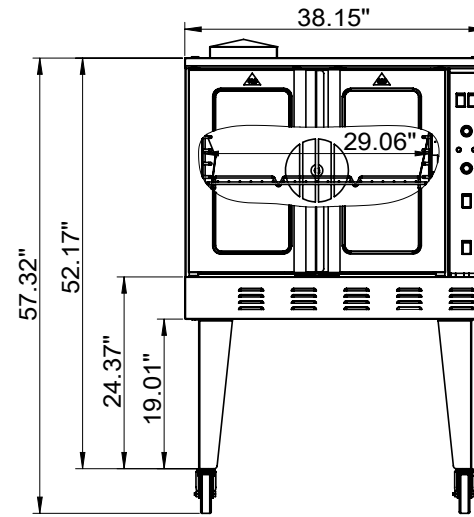

HDSGCO-1

MODEL	DESCRIPTION	TOTAL INPUT (btu/hr)	VOLTAGE/AMP	PRODUCT (WxDxH)	PACKING (WxDxH)	NW	GW
HDSGCO-1	Convection Oven	54,000	120VAC, 60Hz, 9.3A	969 x 1033 x 1456 mm 38.2 x 40.7 x 57.3 inch	1180 x 1070 x 1070 mm 46.5 x 42.1 x 42.1 inch	185 kg 407 lbs	275 kg 605 lbs

sales@heavydutysystems.com